

REV	DESCRIPTION	DATE	APPR

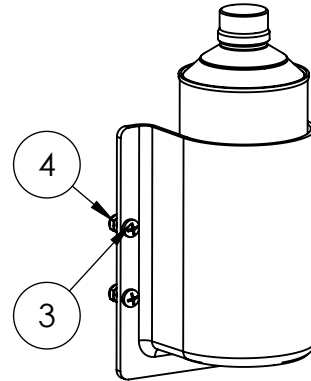

STD. MOUNTING

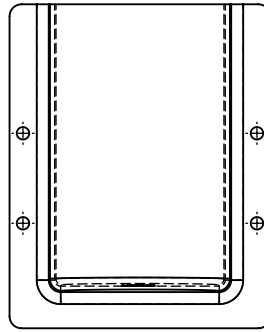
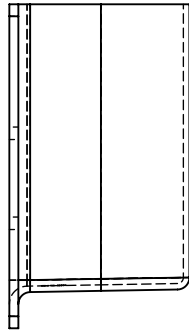
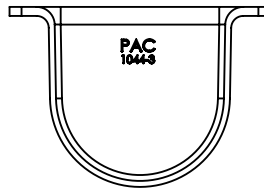
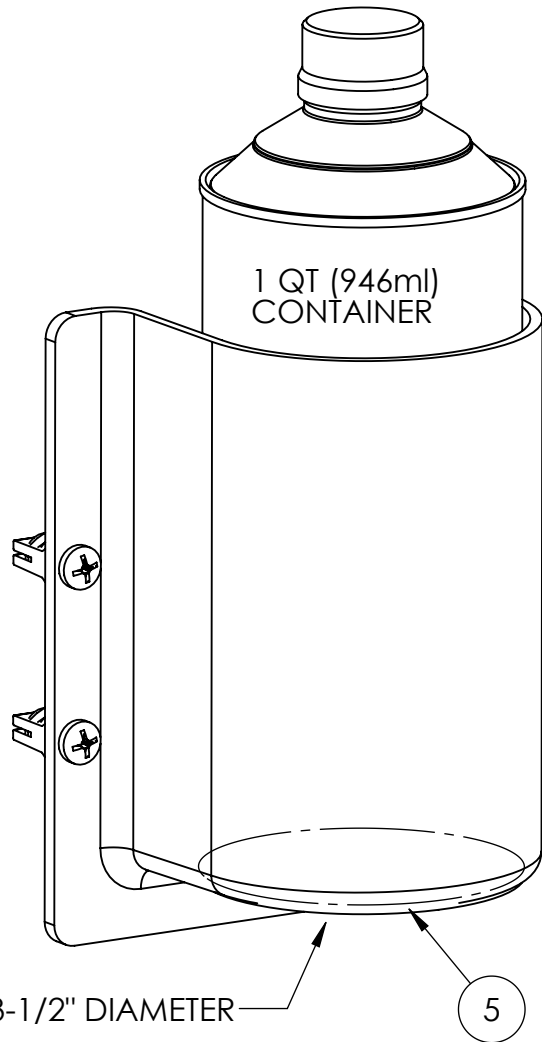
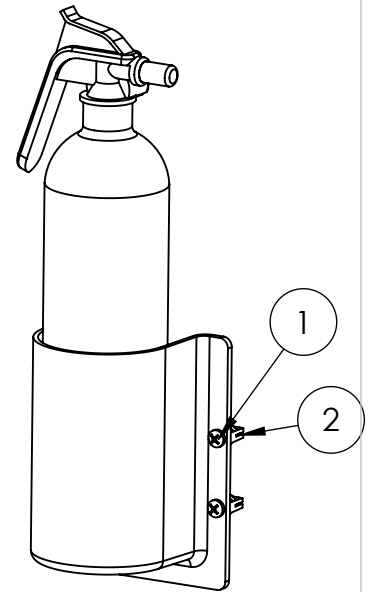

PAC TRAC MOUNTING

5	1044-3P	3-1/2" CYLINDER MOUNT	1
4	2069LN	1/4-20 NYLON LOCK NUT	4
3	2098	14-20 X 34 PHIL PANHEAD	4
2	7016	TRAC LOK INSERT	4
1	2049	#10-24 X 3/4 PAN HEAD SCREW	4
ITEM NO.	PAC P/N	PART NAME	QTY.

NOTES:
 MAX DIAMETER : 3-1/2"
 _____ LB (KG)CAPACITY
 PAC TRAC COMPATIBLE
 CHEMICAL RESISTANT MATERIAL
 FLAME RETARDANT

**PERFORMANCE
 ADVANTAGE
 COMPANY**



TOLERANCES UNLESS OTHERWISE SPECIFIED

.X= ±.03
 .XX= ±.010
 .XXX= ±.005
 .XXXX= ±0.0005
 ANGLES ±0.5 °
 FRACTIONAL ±1/64

THIRD ANGLE PROJECTION

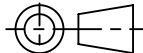

COLOR

NAME	DATE
DRAWN BY	
APPR. BY	
MFG BY	
MFG. P/N	
ENG APPR.	
MATERIAL	
ALT. MATERIAL	
FINISH	

THE INFORMATION CONTAINED IN THIS DRAWING IS THE SOLE PROPERTY OF PERFORMANCE ADVANTAGE CO. ANY REPRODUCTION IN PART OR AS A WHOLE WITHOUT THE WRITTEN PERMISSION OF PERFORMANCE ADVANTAGE CO. IS PROHIBITED.

TITLE:

3-1/2" CYLINDER MOUNT
 TALL

PART NUMBER

1044-3

REV

SCALE: 1:4

SHEET 1 OF 1