

vft3 Sawyer Kit Helmet

Certified - Model: VF3 WILDFIRE

Ergonomics and versatility
with a high level of protection.

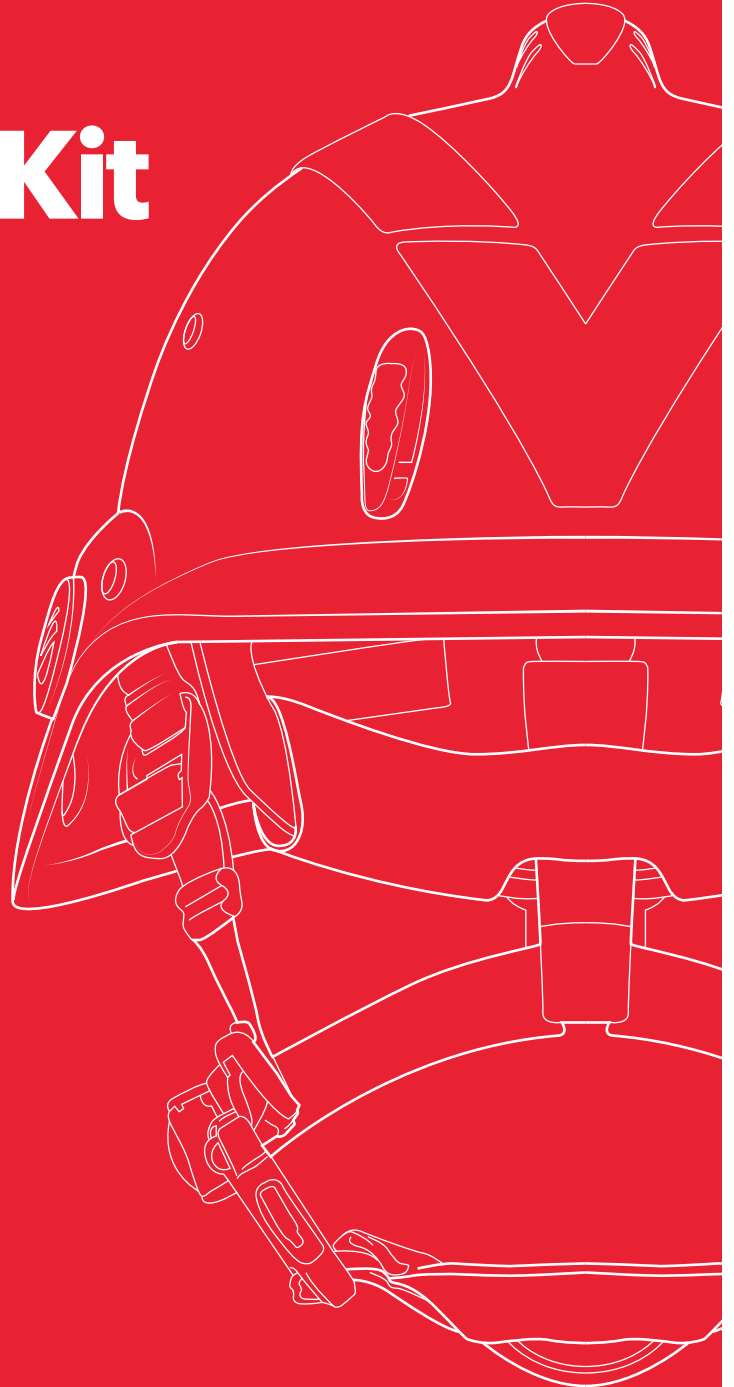

vft3 Sawyer Kit Helmet

Ergonomics and versatility with a high level of protection.

The **vft3 Sawyer Kit Helmet** was designed to meet the needs of units that intervene in wildland fires and rescue operations. Made with high-quality materials, it offers a high level of protection with a wrap-around design produced in a single PC/ABS part without added paint and a protective visor for more protection against liquids from aerial discharges with flame retardant.

Greater protection and resistance

A wrap design for better protection from side, front and rear impacts manufactured with one sole PC/ABS part, without any added paint.

More comfortable and breathable

Completely size adjustable with an adjustment wheel¹. The breathable and fireproof cushioned leather pads form a totally ergonomic and comfortable harness.

Customization

A large variety of colors available, reflective strips with marking and the possibility of adding a shield.



Helmet info

Standards

NFPA 1977-2016

Standard on Protective Clothing and Equipment for Wildland Fire Fighting

Technical specifications

Shell material

PC/PBT.

Inner material

Breathable leather.

Available colors

Yellow, orange, red, gray, black, white, blue and green.

Sizes

21.25 - 24.40 in | 52 - 64cm

Dimensions

10.6 x 9.6 x 6.5 in | 27.7 x 24.5 x 16.4 cm

Helmet Weight

1.25 lbs ± 0.04 lbs | 570g ± 20g

Total Weight

2.03 lbs ± 0.04 lbs | 926g ± 20g

(Weight Helmet + Sawyer Kit)

1 Shell

Features

- Made of PC/PBT.
- The color is integrated with the injection of the material. No added paint.
- Available colors: yellow, orange, red, gray, black, white, blue and green.
- Reflective strip colors: yellow.
- Customization. Reflective strips with marking and the possibility of adding a shield.

Reflective strip color



Colors



2 Harness

Inner harness with 6 anchoring points to the shell. A multi-size system with an adjustment wheel in the back for adaptation to any head.

Features

- Size adjustment with an adjustment wheel from 21.25 - 24.40 in.
- Ergonomic crown pad.
- Cushioned and breathable leather.
- Replaceable and washable protective textile.



3 Chin Strap

Made of fire-retardant fabric and leather. 3-point anchoring to the shell.

Five adjustment points:

- 1 Neck perimeter adjustment.
- 2 Ear height adjustment.
- 3 Height adjustment.
- 4 Sliding removable chin strap.
- 5 Adjustable chin guard.

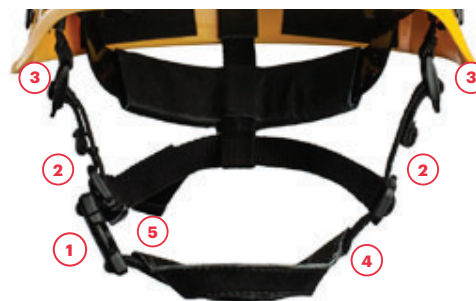

Raised view

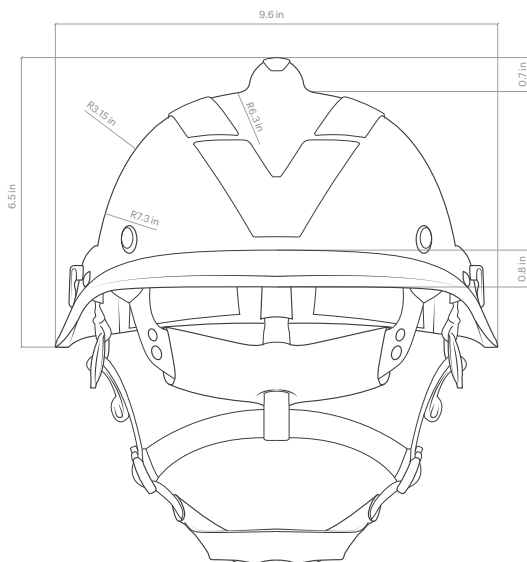

Profile

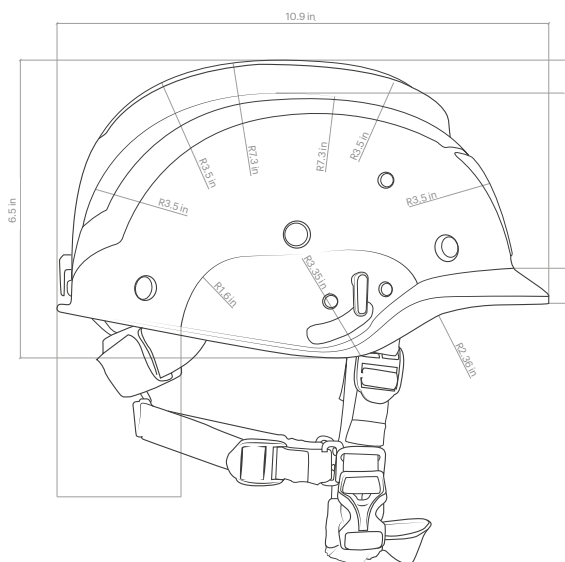

4 Sawyer Kit Components

The vft3 Sawyer Kit Helmet is compatible with all types of accessories. Noise protection, nape guards, radio systems and video cameras can be included.

Safe 2 Flex Visor Carrier

The Safe 2 visor carrier is designed to be combined with safety helmets and visors, with or without hearing protection.

- For straight brimmed helmets.
- Extra rubber seal against rain and debris.



Mesh Screen Visor

The steel mesh visor is very robust and suitable for tough working conditions. The visor protects the wearer from large dust particles and gives a comfortable airflow, stays close to your face for superior coverage and ensures stability and balance.

- Light transmittance of up to 70%.
- Suitable for forestry.



Hearing Protectors

The headband style hearing protectors offer great comfort and quality to all professional users. Protection level 2 is suitable for medium to high noise levels, between 90-110 dB.

- Protection level 2 for medium to high noise.
- Best choice for high frequency noise.
- Comfortable headband with soft padding.



Other accessories

Nape guard

- Nape guard made of 65% Lenzing® F.R. | 30% Nomex® | 5% Kevlar® for perfect insulation against radiation and high temperatures.
- Light.
- Breathable.
- Velcro® attachment.



- * Useful life: 5 years.
- * Warranty: 2 years for the helmet and accessories.