



CIRCUL-AIR SOFT-MOUNT EXTRACTOR

**NFPA 1851:2020
COMPLIANT**

Item # CACSM-35-Pro

DIMENSIONS OF THE WASHER:

LENGTH: 29.0" (L)

DEPTH: 32.0" (D)

HEIGHT: 40.8" (H)

DEPTH (DOOR OPEN): 53.9"

WEIGHT: 221 lbs

SHIP WEIGHT: 300 lbs

PERMISSIBLE WATER PRESSURE: 20 - 120 psi

MAX SPIN - 100 G Force

POWER SUPPLY: 120 V~ 60 Hz



PRODUCT FEATURES

DIRECT DRIVE SYSTEM

The advanced brushless DC motor drives the drum directly without using a belt and pulley.

TILTED DRUM AND EXTRA-LARGE DOOR OPENING

The tilted drum and extra-large opening make it possible to load and unload clothing more easily.

ULTRA CAPACITY

The larger drum enables more tumbling action and greater centrifugal force, but also less tangling and wrinkling of the laundry.

SEE-THROUGH DOOR AND BIG DOOR

You can see the laundry throughout the cycle.

MAGNETIC DOOR PLUNGER

Safely and conveniently secure the door slightly ajar with the magnetic door plunger. This will promote air circulation and allow the interior of the machine to dry. To use this feature, after the load has been removed, do not close the door completely. When the magnetic door plunger comes into contact with the metal washer cabinet, it will secure the door slightly open allowing the interior of the washer to dry.

STAINLESS STEEL DRUM

Stainless steel drum offers extreme durability.

IMPORTANT SAFETY INSTRUCTIONS

READ ALL INSTRUCTIONS BEFORE USE

⚠ WARNING

For your safety, the information in this manual must be followed to minimize the risk of fire or explosion, electric shock, or to prevent property damage, injury to persons, or death.

Your Safety and the safety of others are very important.

We have provided many important safety messages in this manual and on your appliance. Always read and obey all safety messages.

⚠ This is the safety alert symbol.

This symbol alerts you to potential hazards that can kill or hurt you and others.

All safety messages will follow the safety alert symbol and either the word DANGER, WARNING or CAUTION.

These words mean:

⚠ DANGER

You will be killed or seriously injured if you don't immediately follow instructions.

⚠ WARNING

You can be killed or seriously injured if you don't follow instructions.

⚠ CAUTION

You may be slightly injured or cause damage to the product if you do not follow instructions.

All safety messages will tell you what the potential hazard is, tell you how to reduce the chance of injury, and tell you what can happen if the instructions are not followed.

IMPORTANT SAFETY INSTRUCTIONS

READ ALL INSTRUCTIONS BEFORE USE

▲ WARNING

For your safety, the information in this manual must be followed to minimize the risk of fire or explosion, electric shock, or to prevent property damage, injury to persons, or death.

BASIC SAFETY PRECAUTIONS

▲ WARNING

To reduce the risk of fire, electric shock, or injury to persons when using this appliance, follow basic precautions, including the following.

- Before use, the washer must be properly installed as described in this manual.
- Do not wash articles that have been previously cleaned in, washed in, soaked in, or spotted with gasoline, dry-cleaning solvents, or other flammable or explosive substances, as they give off vapors that could ignite or explode.
- Do not add gasoline, dry-cleaning solvents, or other flammable or explosive substances to the wash water. These substances give off vapors that could ignite or explode.
- Under certain conditions, hydrogen gas may be produced in a hot water system that has not been used for 2 weeks or more. **HYDROGEN GAS IS EXPLOSIVE.** If the hot water system has not been used for such a period, before using the washer, turn on all hot water faucets and let the water flow from each for several minutes. This will release any accumulated hydrogen gas. As the gas is flammable, do not smoke or use an open flame during this time.
- Do not allow children to play on or in the washer. Close supervision of children is necessary when the washer is used near children.
- Before the washer is removed from service or discarded, remove the door to prevent children from climbing inside.
- Do not install or store the washer where it will be exposed to the weather or freezing temperatures.
- Do not tamper with controls.
- Do not repair or replace any part of the washer or attempt any servicing other than as described in this manual. We strongly recommend that any service be performed by a qualified technician.
- See Installation Instructions for grounding requirements.
- ALWAYS follow the fabric care instructions supplied by the garment manufacturer.
- Do not place items exposed to cooking oil in your washer. Items contaminated with cooking oils may contribute to a chemical reaction that could cause a load to catch fire.
- This washer is not designed for maritime use or mobile installations such as in RVs, aircraft, etc.
- Turn off the water faucets and unplug the washer if the machine is to be left for an extended period, such as during vacations.
- Packaging material can be dangerous for children. There is a risk of suffocation! Keep all packaging from children.
- Always check the inside of the washer for foreign objects before loading laundry. Keep the door closed when not in use.
- Do not reach into the appliance if the tub is moving.
- **WARNING:** This product contains chemicals known to the State of California to cause cancer and birth defects or other reproductive harm. *Wash hands after handling.*

GROUNDING INSTRUCTIONS

This appliance must be grounded. In the event of malfunction or breakdown, grounding will reduce the risk of electric shock by providing a path of least resistance for electric current. This appliance is equipped with a cord having an equipment-grounding conductor and grounding plug. The plug must be plugged into an appropriate outlet that is properly installed and grounded by all local codes and ordinances.

▲ WARNING

Improper connection of the equipment-grounding conductor can result in a risk of electric shock. Check with a qualified electrician or servicer if you are in doubt as to whether the appliance is properly grounded. Do not modify the plug provided with the appliance. If it does not fit the outlet, have a proper outlet installed by a qualified electrician. Failure to follow these warnings can cause serious injury, fire, electric shock, or death.

IMPORTANT SAFETY INSTRUCTIONS

READ ALL INSTRUCTIONS BEFORE USE

▲ WARNING

For your safety, the information in this manual must be followed to minimize the risk of fire or explosion, electric shock, or to prevent property damage, injury to persons, or death.

SAFETY INSTRUCTIONS FOR INSTALLATION

▲ WARNING

To reduce the risk of fire, electric shock, or injury to persons when using this appliance, follow basic precautions, including the following.

- Refer to **INSTALLATION INSTRUCTIONS** for detailed grounding procedures. Installation instructions are packed with the washer for the installer's reference. If the washer is moved to a new location, have it checked and reinstalled by a qualified service technician. Failure to follow this warning can cause serious injury, fire, electric shock, or death.
- Do not, under any circumstances, cut or remove the third (ground) prong from the power cord. Failure to follow this warning can cause serious injury, fire, electric shock, or death.
- For personal safety, this appliance must be properly grounded. Failure to follow this warning can cause serious injury, fire, electric shock, or death.
- The power cord of this appliance is equipped with a 3-prong (grounding) plug which mates with a standard 3-prong (grounding) wall outlet to minimize the possibility of electric shock from this appliance.
- This washer must be plugged into a 120 VAC, 60 Hz grounded outlet. Failure to follow this warning can cause serious injury, fire, electric shock, or death.
- Have the wall outlet and circuit checked by a qualified electrician to make sure the outlet is properly grounded. Failure to follow this warning can cause serious injury, fire, electric shock, or death.
- Where a standard 2-prong wall outlet is encountered, it is your responsibility and obligation to have it replaced with a properly grounded 3-prong wall outlet. Failure to follow this warning can cause serious injury, fire, electric shock, or death.
- Do not install on carpet. Install washer on a solid floor. Failure to follow this warning can cause serious leak damage.
- Do not remove the ground prong. Do not use an adapter or extension cord. Plug into a grounded 3-prong outlet. Failure to follow these warnings can cause serious injury, fire, electric shock, or death.
- The washer should always be plugged into its electrical outlet which has a voltage rating that matches the rating plate. This provides the best performance and also prevents overloading house wiring circuits which could cause a fire hazard from overheated wires.
- Never unplug your washer by pulling on the power cord. Always grip the plug firmly and pull straight out from the outlet. Failure to follow this warning can cause serious injury, fire, electric shock, or death.
- Repair or immediately replace all power cords that have become frayed or otherwise damaged. Do not use a cord that shows cracks or abrasion damage along its length or at either end. Failure to follow this warning can cause serious injury, fire, electric shock, or death.
- When installing or moving the washer, be careful not to pinch, crush, or damage the power cord. Failure to follow this warning can cause serious injury, fire, electric shock, or death.
- The washer must be installed and electrically grounded by a qualified service person by local codes to prevent shock hazards and assure stability during operation.
- The washer is heavy. Two or more people may be needed to install and move the appliance. Failure to do so can result in back or another injury.
- Store and install the washer where it will not be exposed to temperatures below freezing or exposed to outdoor weather conditions. Failure to follow this warning can cause serious leak damage.
- Do not install the washer in humid spaces to reduce the risk of electric shock. Failure to follow this warning can cause serious injury, fire, electric shock, or death.
- To reduce the risk of injury to persons, adhere to all industry-recommended safety procedures including the use of gloves and safety glasses. Failure to follow all of the safety warnings in this manual could result in property damage, injury to persons, or death.

IMPORTANT SAFETY INSTRUCTIONS

READ ALL INSTRUCTIONS BEFORE USE

▲ WARNING

For your safety, the information in this manual must be followed to minimize the risk of fire or explosion, electric shock, or to prevent property damage, injury to persons, or death.

SAFETY INSTRUCTIONS FOR USE, CARE, CLEANING, AND DISPOSAL

▲ WARNING

To reduce the risk of fire, electric shock, or injury to persons when using this appliance, follow basic precautions, including the following.

- Unplug the washer before cleaning to avoid the risk of electric shock.
- Never use harsh chemicals, abrasive cleaners, or solvents to clean the washer. They will damage the finish.
- Do not put oily or greasy rags or clothing on top of the washer. These substances give off vapors that could ignite the materials.
- Do not wash items that are soiled with vegetable or cooking oil. These items may contain some oil after laundering. Due to the remaining oil, the fabric may smoke or catch fire by itself.
- Disconnect this appliance from the power supply before attempting any user maintenance. Turning the controls to the OFF position does not disconnect this appliance from the power supply. Failure to follow this warning can cause serious injury, fire, electric shock, or death.
- Do not combine laundry products for use in one load unless specified on the label.
- Do not mix chlorine bleach with ammonia or acids such as vinegar. Follow package directions when using laundry products. Incorrect usage can produce poisonous gas, resulting in serious injury or death.
- Do not reach into the washer while parts are moving. Before loading, unloading, or adding items, press the START/PAUSE button and allow the drum to coast to a complete stop before reaching inside. Failure to follow this warning can cause serious injury, fire, electric shock, or death.
- Do not allow children to play on or in the washer. Close supervision of children is necessary when the washer is used near children. As children grow, teach them the proper, safe use of all appliances. Failure to comply with these warnings could result in serious injury to persons or death.
- Destroy the carton, plastic bag, and other packing materials after the washer is unpacked. Children might use them for play. Cartons covered with rugs, bedspreads, or plastic sheets can become airtight chambers. Failure to comply with these warnings could result in serious injury to persons or death.
- Keep laundry products out of children's reach. To prevent injury to persons, observe all warnings on product labels. Failure to comply with these warnings could result in serious injury to persons or death.
- Remove the door to the washing compartment to avoid the danger of children or small animals getting trapped inside before your washer is removed from service or discarded. Failure to do so can result in serious injury to persons or death.

SAVE THESE INSTRUCTIONS

PARTS AND ACCESSORIES

Parts

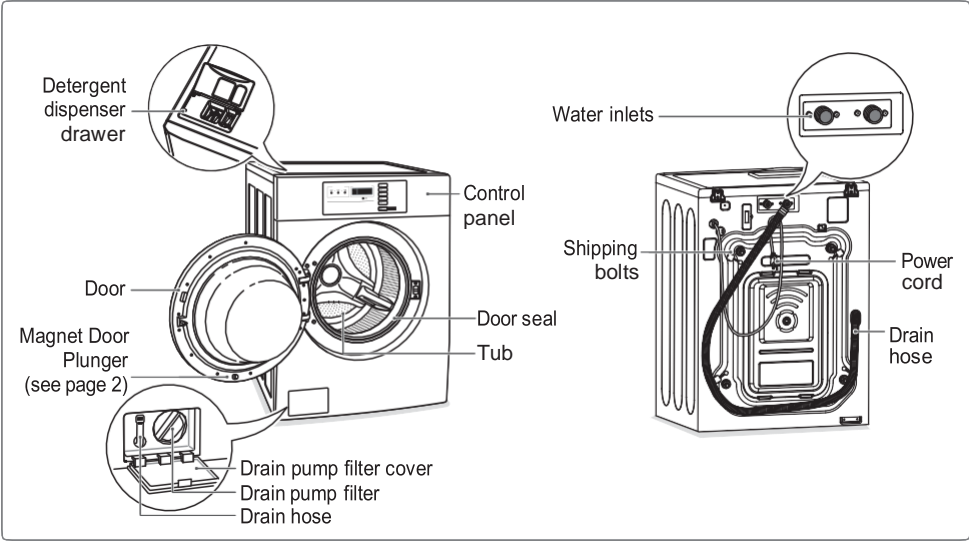

Accessories

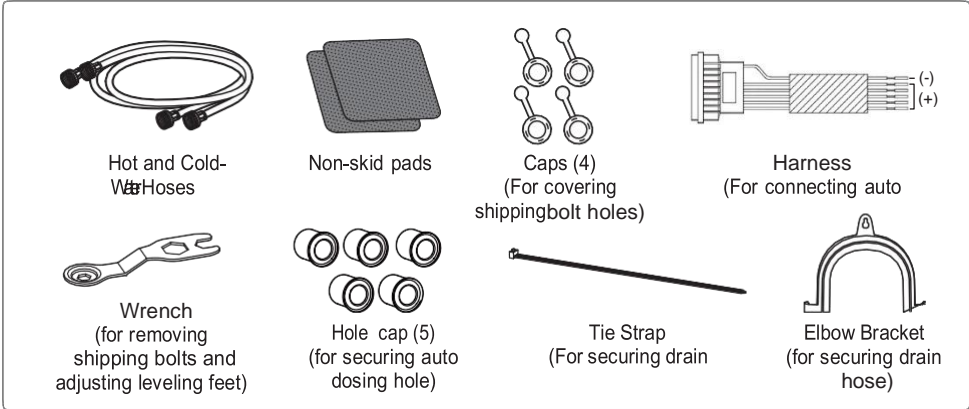

CONTROL PANEL FEATURES

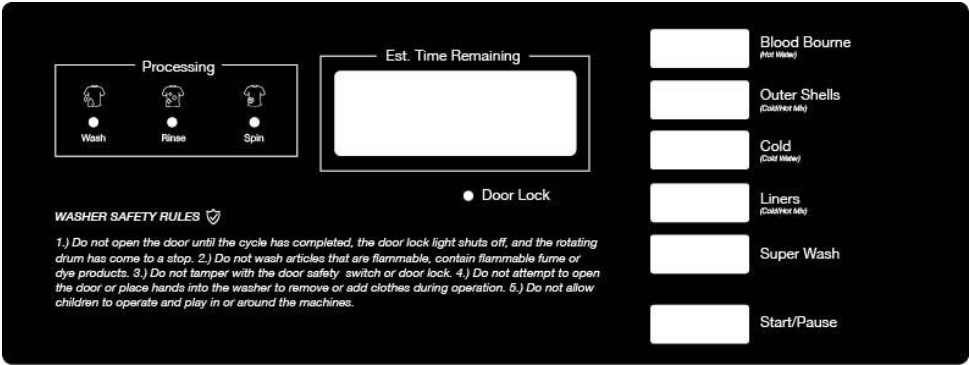

Display LED

The display shows the remaining time and programming options. Error codes are also displayed here.



Optional cycle

Super Wash: Wash cycle with longest run time.

Start/Pause button

The Start/Pause LED flashes when the cycle has been chosen.

Status LED

Cycle button

Press the CYCLE button to select the desired cycle based on laundry types and conditions.

Blood Borne

Increased temperature for cleaning heavilysoiled clothing.

Outer Shells





Use for warm washing for heavy external fabrics.

Cold

Use for cold washing for sturdy fabrics, such as in-station clothing.

Liners

Use for warm washing for internal fabrics.

LED	Description
 Wash	LED flashes whenever the washing cycle is in operation.
 Rinse	LED flashes whenever the rinsing cycle is in operation.
 Spin	LED flashes whenever the spinning cycle is in operation.
 Door Lock	LED flashes whenever the door lock is activated.

INSTALLATION INSTRUCTIONS

Checking and choosing the proper location

Install the washing machine on a solid floor that is strong and rigid enough to support the weight of the washing machine, even when fully loaded, without flexing or bouncing. If the floor has too much flex, you may need to reinforce it to make it more rigid. If the floor is not solid, it may cause severe vibration and noise.

- 1 Clean the floor before installation.
 - Make sure to select solid and smooth ground.
- 2 Two or more people are needed for moving and unpacking the washing machine.
- 3 Allow for sufficient space between the walls and the washing machine for installation.

Space requirements

You must allow sufficient space for water lines, the drain line, and airflow.

NOTE

- Be sure to allow for wall, door, or floor moldings that may increase the required clearances.

Installing on a floor

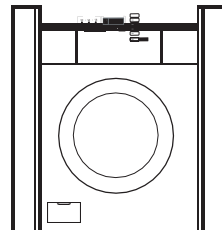
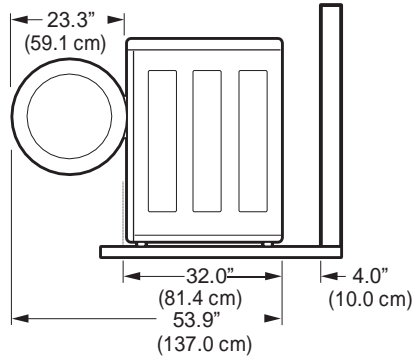

NOTE

- The floor must be strong and rigid enough to support the weight of the washer, when fully loaded, without flexing or bouncing. If your floor has too much flex, you may need to reinforce it to make it more rigid. A floor that is adequate for a top-loading washer may not be rigid enough for a front-loading washer, due to the difference in the spin speed and direction. If the floor is not solid, your washer may vibrate and you may hear and feel the vibration throughout your house.
- Before installing the washer, make sure the floor is clean, dry and free of dust, dirt, water and oils so the washer feet cannot slide easily. Leveling feet that can move or slide on the floor can contribute to excess vibration and noise due to poor contact with the floor.

Unpacking and removing shipping bolts

When removing the washer from the carton base, be sure to remove the foam drum support in the middle of the carton base. If you must lay the washer down to remove the base packaging materials, always lay it carefully on its side. DO NOT lay the washer on its front or back.

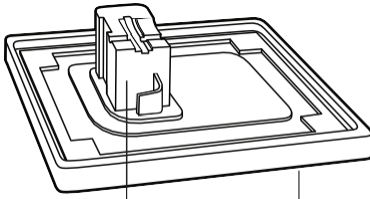

Foam Tub Support Carton Base

- 1 Remove the bottom two shipping bolts with the wrench (included) to fully loosen all shipping bolts by turning them counterclockwise and then pulling them out.

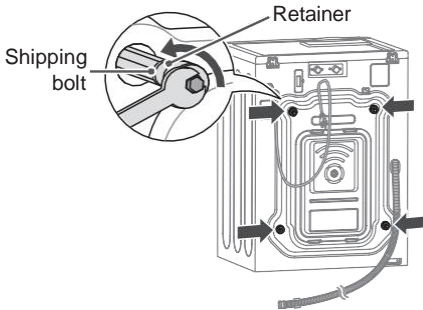

- 2 Locate the four-hole caps included in the accessory pack and install them in the shipping bolt holes.

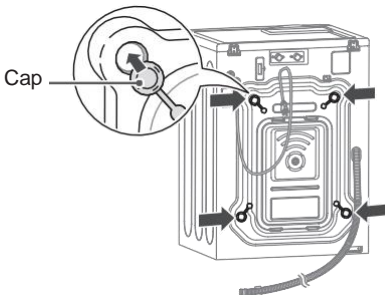

NOTE

- Save the bolt assemblies for future use. To prevent damage to internal components, DO NOT transport the washer without reinstalling the shipping bolts.
- Failure to remove shipping bolts and retainers may cause severe vibration and noise, which can lead to permanent damage to the washer. The cord is secured to the back of the washer with a shipping bolt to help prevent operation with shipping bolts in place.

Installing Hole cap

- 1 Use provided hole caps.



- 2 Insert the hole cap (5 pieces) into the connected section back of the machine.

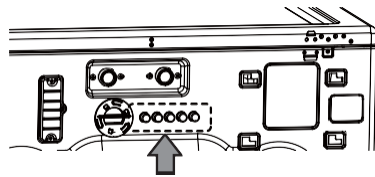

NOTE

- In case of using auto dosing feature, inserting hole cap is unnecessary.

Connecting the water lines

- 1 Check the rubber seals on both sides of the hose.

- Insert a rubber seal into the threaded fittings on each hose to prevent leaking.

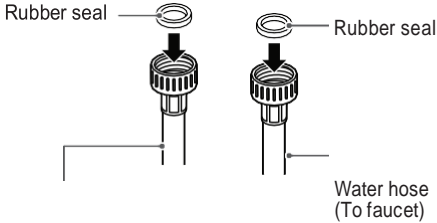

Water hose
(To water inlet on the
washing machine)

- 2 Connect the water supply hoses to the HOT and Cold-water faucets tightly by hand and then tighten another 2/3 turn with pliers.

- Connect the blue hose to a cold-water faucet and the red hose to a hot water faucet.

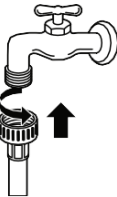

⚠ WARNING

- Do not overtighten. Damage to the coupling can result.

- 3 After connecting the inlet hose to water faucets, turn on the water faucets to flush out foreign substances (dirt, sand, sawdust) in the water lines. Let water drain into a bucket, and check the water temperature.

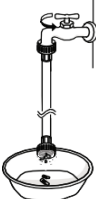

- 4 Connect the hoses to the water inlets tightly by hand and then tighten another 2/3 turn with pliers.

- Connect the blue hose to the cold-water inlet and the red hose to the hot water inlet.

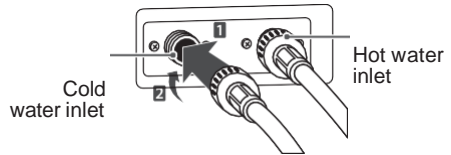

⚠ WARNING

- Do not overtighten the hoses. Overtightening can damage the valves resulting in leaking and property damage.

- 5 Check for leaks by turning on the faucets.
- If water leaks, check steps 1 to 4 again.

ⓘ NOTE

- For your safety, and for extended product life, use only authorized components. The manufacturer is not responsible for product malfunction or accidents caused by the use of separately purchased unauthorized parts.
- Use new hoses when you install the washing machine. Do not reuse old hoses. Use only the inlet hoses provided with the washer.
- Periodically check the hoses for cracks, leaks and wear, and replace the hoses every 5 years.
- Do not stretch the water hoses intentionally, and make sure that they are not crushed by other objects.
- Water supply pressure must be between 20 PSI and 120 PSI (138–827 kPa). If the water supply pressure is more than 120 PSI, a pressure reducing valve must be installed.
- To provide optimum washing performance the hot water temperature should be set at 100°F (38°C) and the cold at 60°F (15°C).

Connecting the drain line

Secure the drain hose in place to prevent moving and leaking.

NOTE

- The drain hose should be properly secured. Failure to properly secure the drain hose can result in flooding and malfunction.
- Total height of the hose end should not exceed 96 inches (244.8 cm) from the bottom of the washer.
- The drain must be installed in accordance with any applicable local codes and regular-tons.
- Make sure that the water lines are not stretched, pinched, crushed, or kinked.

Using a standpipe

- 1 Clip the end of the hose into the elbow bracket.
 - Connect the elbow bracket within 4 inches (10 cm) from the end of the drain hose. If the drain hose is extended more than 4 inches (10 cm) beyond the end of the elbow bracket, mold or microorganisms could spread to the inside of the washer.

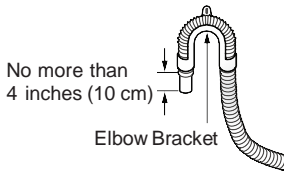

- 2 Insert the end of the drain hose into the standpipe.

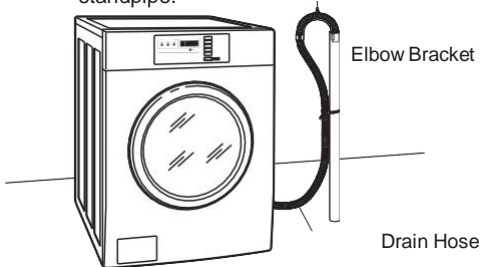

- 3 Use a tie strap to secure the drain hose in place.

Using a laundry tub

- 1 Clip the end of the hose into the elbow bracket.
 - Connect the elbow bracket within 4 inches (10 cm) from the end of the drain hose. If the drain hose is extended more than 4 inches (10 cm) beyond the end of the elbow bracket, mold, or microorganisms could spread to the inside of the washer.

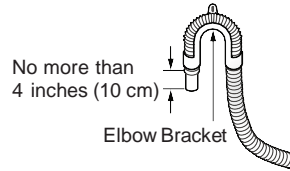

- 2 Hang the end of the drain hose over the side of the laundry tub.

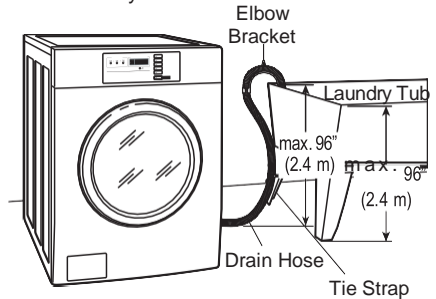

- 3 Use a tie strap to secure the drain hose in place.

Connecting the auto dosing

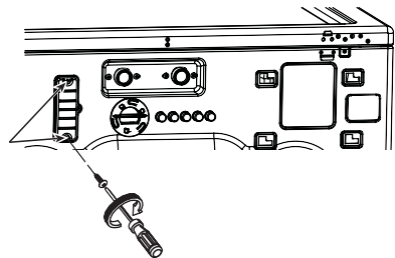

- 1 Unscrew the 2 screws on the protective cover.
- 2 Remove the protective cover.
- 3 Connect the auto dosing harness from Accessory parts.

Leveling the washing machine

The washer tub of your new washing machine spins at very high speeds. To minimize vibration, noise, and unwanted movement, the floor must be perfectly level and solid.

- 1 Check the washing machine's level.
 - Check the precise level by rocking the top edges of the washing machine or placing a level on the washing machine. The slope beneath the washing machine must not exceed 1°, and all four leveling feet must rest firmly on the floor.

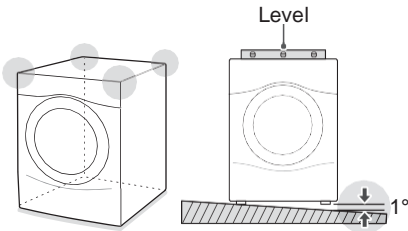

- 2 Turn the lower leveling feet clockwise to level the washing machine.
 - Turning the lower leveling feet clockwise raises the washing machine.

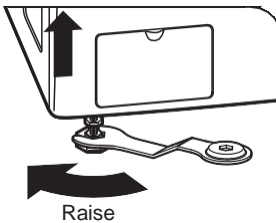

- 3 Turn the locknuts counterclockwise and tighten them when the washing machine is level.

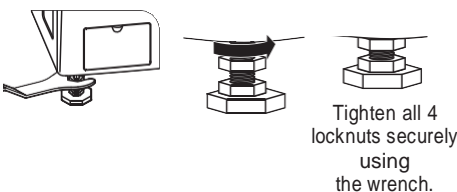

- 4 Check the washing machine's level again.
 - Push or rock the top edges of the washing machine gently to make sure that the washing machine does not rock.
 - If the washing machine rocks, repeat steps 1 to 3.

⚠ WARNING

- Using the washing machine without leveling, it may result in malfunction caused by the production of excess vibration and noise.
- Use the leveling feet only when you level the washing machine. If you raise the leveling feet unnecessarily, it may cause abnormal vibration of the washing machine.

Using non-skid pads (optional)

If you install the washing machine on a slippery surface, it may move because of excessive vibration. Incorrect leveling may cause malfunction through noise and vibration. In the event of this, lay the non-skid pads under the leveling feet and adjust the level.

- 1 Clean the floor to attach the non-skid pads.
 - Use a dry rag to remove and clean foreign objects or moisture. If moisture remains, the non-skid pads may slip.
- 2 Adjust the level after placing the washing machine in the installation area.
- 3 Place the adhesive side of the non-skid pad on the floor.
 - It is most effective to install the non-skid pads under the front legs. If it is hard to place the pads under the front legs, place them under the back legs.

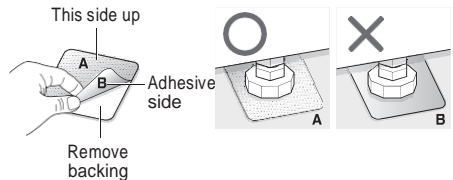

- 4 Check the washing machine's level again.
 - Push or rock the top edges of the washing machine gently to make sure that the washing machine does not rock. If the washing machine rocks level the washing machine again.

OPERATING YOUR WASHER

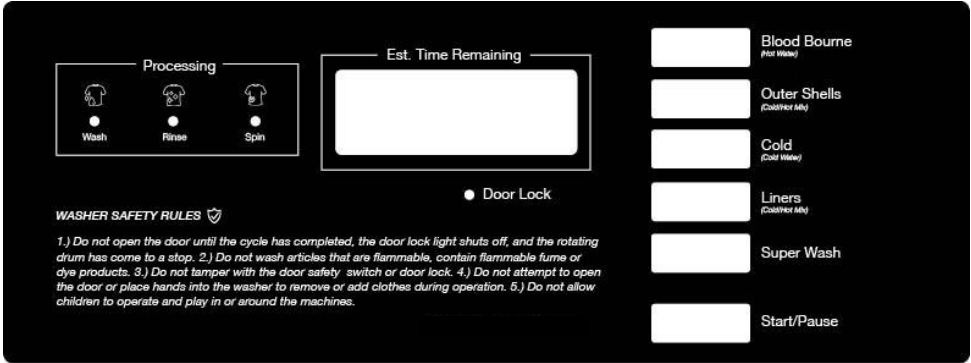

1. Ready mode

The cycle LEDs flash at the same time and display PUSH.

2. Select the cycle

Press the desired button and press the Start button. The display LED will show the remaining time and the selected cycle start.

3. Change course

You cannot change the cycle while the machine is running.

4. Cycle finish

The machine stops and the LED display shows "End" with a beeper sound.

- Do not work any button and stop the washer (when the washer is operating) or (when a cycle is in progress).

WARNING

- To reduce the risk of fire, electric shock, or injury to persons, read the IMPORTANT SAFETY INSTRUCTIONS before operating this appliance.

MAINTENANCE

Cleaning the door seal

Clean the door seal once a month to prevent the build-up of dirt in the door seal.

- 1 Wear rubber gloves and protective goggles.
- 2 Dilute 3/4 cup (177 ml) of liquid chlorine bleach in 1 gallon (3.8 L) of water.
- 3 Soak a sponge or a soft cloth in this diluted solution and wipe down all around the door seal.
- 4 Wipe any moisture with a dry towel or cloth after cleaning.
- 5 Leave the door open to allow the door seal to dry completely.

CAUTION

- Cleaning the door seal with an undiluted solution may cause malfunction of the door seal and washing machine parts.

Cleaning the dispenser

- 1 The dispenser should be cleaned periodically to remove buildup from detergent and other laundry products.



- 2 Remove inserts from the drawer and clean them with warm water and a soft cloth or brush to remove any residue or buildup. Wipe out the inside of the drawer opening with a damp cloth. Reassemble the drawer and reinstall the drawer opening.



NOTE

- Do not use anything other than water to clean the drawer, inserts, and drawer opening.

Cleaning the drum

Using the washing machine in a humid space for a long period may lead to a buildup of black mold and germs in the air inside the washer tub and affect your health. If you clean the washer tub regularly every month Using the "Blood Borne" (hot) cycle will keep the washer tub clean for hygienic use.

- 1 Add tub cleaner or limescale remover into the detergent dispenser drawer.
 - Do not exceed the maximum detergent limit line when you add it. The detergent may remain in the washer tub after cleaning.

2 Run cycle.

NOTE

- Never load laundry while cleaning the tub. The laundry may damage or become contaminated. Make sure to clean the washer tub when it is empty.
- Leave the door open after finishing the laundry to keep the tub clean.
- Cleaning the tub can be repeated monthly.
- Safely and conveniently secure the door slightly ajar with a magnetic door plunger. This will promote air circulation and allow the interior of the machine to dry.

U
S
I
N
G
T
H
E
W
A
S
H
I
N
G
M
A
C
H
I
N
E
I
N
A
H
U
M
I
D
S
P
A
C
E

Cleaning the water inlet filters

Clean the water inlet filters periodically to prevent clogging. Take extra care to clean the water inlet filters for areas using hard water. Water may not be supplied if there are foreign objects, such as rust, sand, or stones in the water inlet filters.

- 1 Pull out the plug to turn off the washing machine.
- 2 Turn off the faucets connected with the water inlets.
- 3 Remove the water inlet hoses.

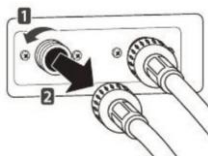

⚠ WARNING

- **Unplug the power cord and turn off the faucets before cleaning.** Failure to do so may cause electric shock.
- **Do not use the washing machine without inlet filters.** If you use the washing machine without the inlet filters, it will cause leaks and malfunction.
- If you use the washing machine in an area with hard water, the inlet filter may clog due to buildup.

ⓘ NOTE

- ***iE*** message will blink on the display when the water pressure in the detergent drawer is weak or an inlet filter is clogged with dirt. Clean the inlet filter.

Cleaning the drain pump filters

The washing machine fails if the drain pump filter is clogged. Periodically clean the drain filter to prevent clogging with foreign objects.

- 1 Pull out the plug to turn off the washing machine.
- 2 Open the drain pump filter cover.

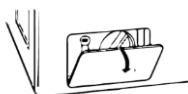

- 3 Unclip the drain hose and remove the plug from the drain hose to drain the remaining water.



- 4 Twist the pump filter counterclockwise to remove.



- 5 Clean the pump filter and opening.



- 6 Recap the plug onto the drain hose and reattach the drain hose.

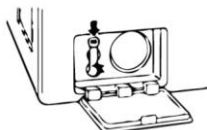

- 7 Insert the drain pump filter.



- 8 Close the drain pump filter cover.

⚠ WARNING







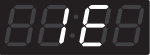
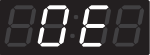

- **Make sure to pull out the plug before Cleaning.** Failure to do so may cause electric shock.
- Opening the drain filter will result in water overflowing if there is water in the washer tub. **Make sure to check if the water is completely drained before opening the drain filter.**
- If you use the washing machine with the drain filter reassembled incorrectly after cleaning it or with no filter, it may cause leaks or malfunction of the machine.

ⓘ NOTE

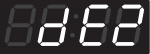
- ***DE*** message will blink when the Drain Pump filter is clogged with dirt. Clean the Drain pump filter.

ERROR MODE

Meaning of Error Codes that LED displays during the occurrence of the problem.

Problem	Possible Cause	Solution
	<ul style="list-style-type: none"> Water supply is not adequate in the area. Water supply taps are not completely open. Water inlet hose is bent. The filter of the inlet hose clogged. 	Check another tap in the house. Fully open tap. Straighten hose. Check the filter of the inlet hose.
	<ul style="list-style-type: none"> Drain hose is bent or clogged. The drain filter is clogged. 	Clean and straighten the drain hose. Clean the drain filter.
	<ul style="list-style-type: none"> Load is too small. Load is out of balance. The appliance has an imbalance detection and correction system. If individual heavy articles are loaded (bath mat, bathrobe, etc.) and the imbalance is too great, after several attempts to restart the spin cycle the machine will stop and the error code will be displayed. 	Add 1~2 similar items to help balance the load. Rearrange load to allow proper spinning.
	<ul style="list-style-type: none"> Is the door opened or not completely closed? 	Close the door completely. * If it will not open, call for service.
	<ul style="list-style-type: none"> Door lock is broken. 	Check the door switch.
	<ul style="list-style-type: none"> The water overfills due to a faulty water valve. 	Close the water tap. Unplug the power plug. Call for service.
	<ul style="list-style-type: none"> The water level sensor malfunctioned. 	
	<ul style="list-style-type: none"> Overloading motor. 	Restart the cycle after 30 minutes. If  is not released, call for service.
	<ul style="list-style-type: none"> Too much detergent is used. 	This is not an error. It indicates a suds removal routine. It will clear and restart the cycle when the suds are gone.
	<ul style="list-style-type: none"> Thermistor is opened or shorted. 	The thermistor should be replaced.

*For further troubleshooting, please contact Circul-Air Corp @ 800-795-1150.

**Please have your product serial number ready before calling.

POWER FAIL RECOVERY

In case of power failure, the machine stops running but the time display remains on, showing the time just before power failure.

SPECIFICATIONS

Model	
Name	Front-loading Washing Machine: CACSM-30
Power supply	120 V~ 60 Hz
Size	29.0" (L) X 32.0" (D) X 40.8" (H), 53.9" (D with door open) 73.7 cm (L) X 81.4 cm (D) X 103.6 cm (H), 137.0 cm (D with door open)
Weight	221 lbs (100.25 kg)
Wash capacity	5.2 cu. ft (IEC: 6.0 cu. ft)
Spin speed	100 G Force
Permissible water pressure	20 - 120 psi (138 ~ 827 kPa)