



PRODUCT DATA SHEET

P/N: **CM6000-12**

CYLINDER MATE 12 PACK CART



The Cylinder Mate Mobile Storage Units are assembled from individual Cylinder Mates. Mobile units allow air cylinders to be moved or relocated easily for transfer or filling.

FEATURES

- Heavy duty pneumatic wheels with locks on front wheels
- Up to 300lb capacity
- Pull handle for easy control
- Empty cylinders can be safely stored and removed when installed backwards with new design

SCBA Cylinder Sizing:

Minimum Diameter = 5-3/8" (136mm)
 Maximum Diameter = 7-1/8" (180mm)
 Maximum Length = 23-1/8" (587mm)

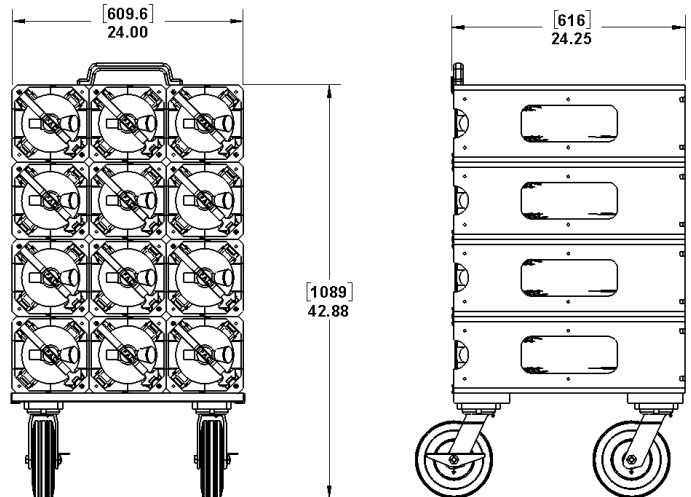

SPECIFICATIONS

P/N	WT.	MAX LOAD	GRIP RANGE	HANGER RANGE	FLAME TOXICITY CHEMICAL
CM6000-12	155 lbs	N/A	N/A	N/A	N/A

Performance Advantage Company Lancaster, New York www.pactoolmounts.com 888-514-0083

REFERENCE	QTY	REMARKS	PROJECT
			LOCATION
			BUYER
			DEALER
			BUILDER
			SUBMITTED BY:
			DATE:



The Cylinder Mate Mobile Storage Units are assembled from individual Cylinder Mates. Mobile units allow air cylinders to be moved or relocated easily for transfer or filling.

- Heavy duty pneumatic wheels with locks on front wheels
- Up to 300lb capacity
- Pull handle for easy control
- Empty cylinders can be safely stored and removed when installed backwards with new design