

REV	DESCRIPTION	DATE	APPR

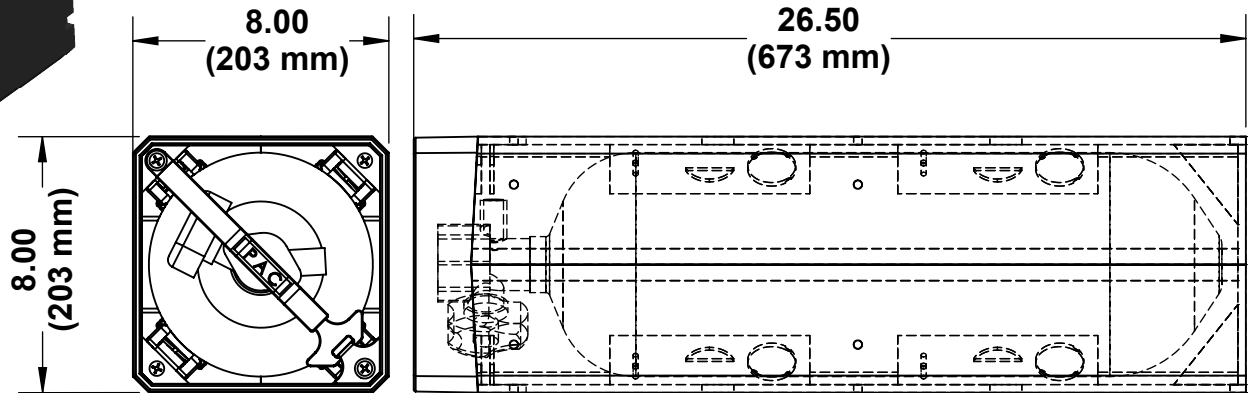
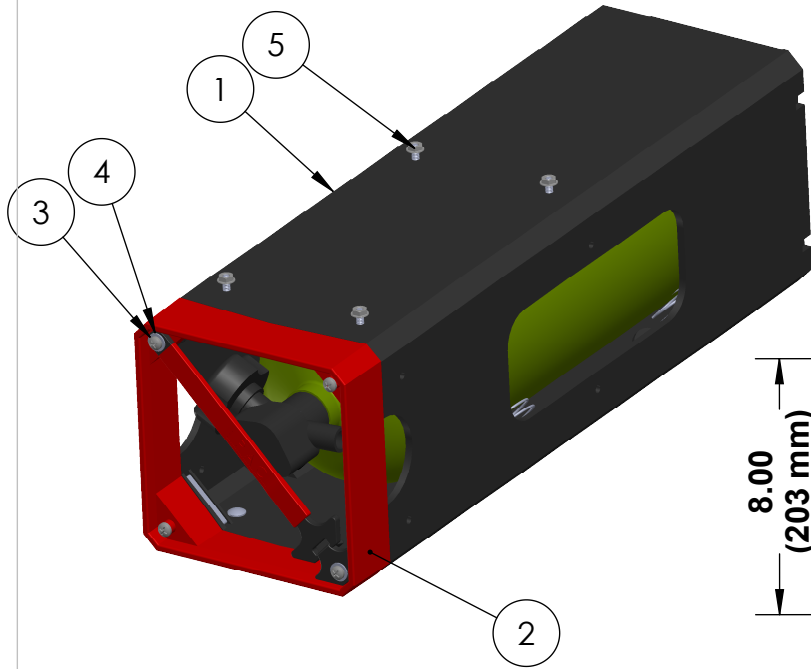

5	7037	FASTENER KIT - CYLINDER MOUNT		1
4	2011	1/4" FLAT WASHER		2
3	3028	14-20 X 2-1/4 PHIL PANHEAD		4
2	CM600-902	BUILD KIT FOR CM6060		1
1	CM600P	CYLINDERMATE BASE ASSEMBLY		1
ITEM NO.	PAC P/N	PART NAME	Color	QTY

NOTES:

SCBA Cylinders Sizing:

Minimum Diameter = 5-3/8" (136mm)
 Maximum Diameter = 7-1/8" (180mm)
 Maximum Length = 25" (635mm)

**PERFORMANCE
 ADVANTAGE
 COMPANY**



TOLERANCES UNLESS OTHERWISE SPECIFIED

.X = ± .03
 .XX = ± .010
 .XXX = ± .005
 .XXXX = ± 0.0005
 ANGLES ± 0.5 °
 FRACTIONAL ± 1/64

THIRD ANGLE PROJECTION



COLOR

NAME	DATE
DRAWN BY	
APPR. BY	
MFG BY	
MFG. P/N	
ENG APPR.	
MATERIAL	
ALT. MATERIAL	
FINISH	

THE INFORMATION CONTAINED IN THIS DRAWING IS THE SOLE PROPERTY OF PERFORMANCE ADVANTAGE CO. ANY REPRODUCTION IN PART OR AS A WHOLE WITHOUT THE WRITTEN PERMISSION OF PERFORMANCE ADVANTAGE CO. IS PROHIBITED.

TITLE:

CYLINDER MATE EXTENDED

PART NUMBER

CM6060

REV

SCALE: 1:6

SHEET 1 OF 2