



# Cylinder Mate P/N CM6060

Extended Version

# INSTALLATION INSTRUCTIONS

For additional assistance call (888)-514-0083 between 8AM-5PM EST or email: info@pactoolmounts.com

## CAUTION

To avoid the risk of personal injury, property damage or product damage, please use the included fasteners for mounting.

- \* This product must be securely mounted to a stable surface and material.
- \* This product contains enough mounting hardware to assemble two Cylinder Mates to each other.
- \* Misuse of this product may result damage or injury and void warranty.
- \* Verify that all fasteners have been tightened securely before putting into service.
- \* Note: All included fasteners may not be utilized for every installation.

### Option 1: Single Cylinder Mate CM6060 Mounting

Position Cylinder Mate in desired location with the non-windowed side on the primary mounting surface. (see **Figure 1A**) Using the included hardware, attach the cylinder mate with (4) Carriage Bolts P/N 2037 and (4) Nuts P/N 2042 to the mounting surface. Installer to locate and drill (17/64) holes for mounting.

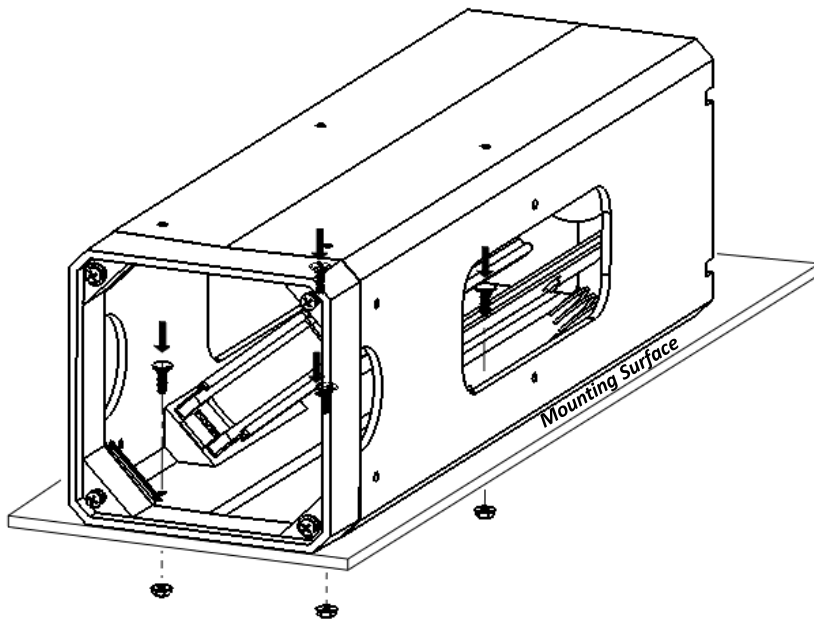







FIGURE 1A

Items Required for this step		Qty
PAC Fastener Kit P/N 7037	 ¼-20 x ¾ Carriage Bolt P/N 2037	4
	 ¼-20 Flanged Nut P/N 2042	4
	Small 7/16 ratcheting Wrench	not included

## Option 2 – Assembly to Additional Cylinder Mate CM6060 Units

PAC Cylinder Mates are designed to be attached together to form storage units. Cylinder Mates can be arranged in various configurations to accommodate storage space.

Items Required for this step		Qty
PAC Fastener Kit P/N 7037	 ¼-20 x ¼ Carriage Bolt P/N 2037	4
	 ¼-20 Flanged Nut P/N 2042	4
	Small 7/16 ratcheting Wrench	not included

When attaching an additional Cylinder Mate to the top of another (**See Figure 2a**), use the same (4) mounting locations as the one below.

When attaching an additional Cylinder Mate to the side of another, use the mounting locations as shown in **Figure 2b**. Only seven fasteners are required for side mounting.

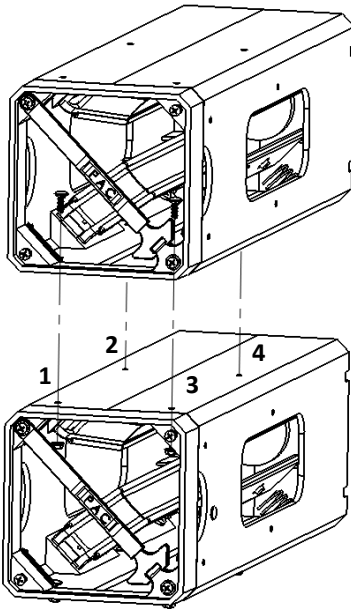

FIGURE 2a

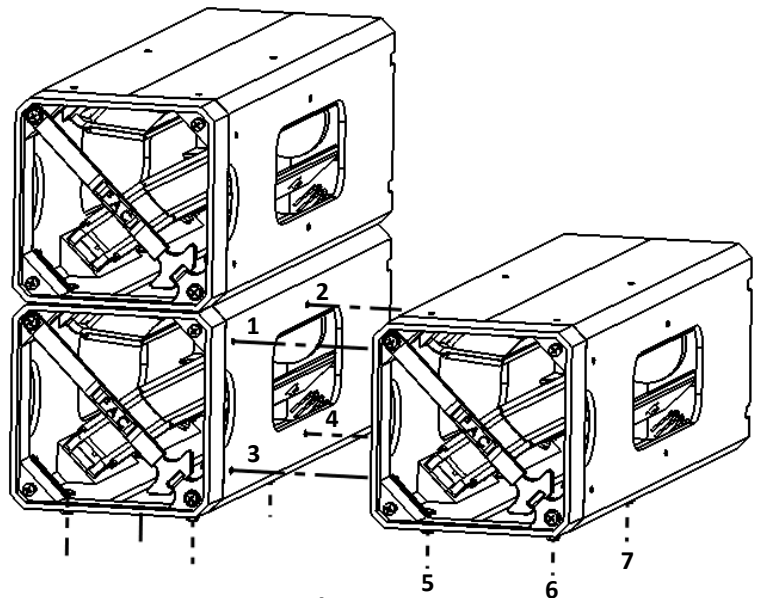

FIGURE 2b