



IRONSLOK HD - P/N K5003HD

INSTALLATION INSTRUCTIONS

For additional assistance call 716-683-7413 between 8AM-5PM EST or email: info@pactoolmounts.com

CAUTION

To avoid the risk of personal injury, property damage or product damage, please use the included fasteners for mounting.

- * The bracket must be securely mounted to a stable surface and material.
- * This product is designed to secure flathead axes with Halligan style tools (Irons). Misuse of this product may result damage or injury and void warranty.
- * Verify that all fasteners have been tightened securely before putting into service.
- * When mounting bracket to PAC TRAC aluminum products **P/N 7000, P/N 7020, P/N 7040, P/N 7050** with the included Trac Lok inserts **P/N 7016**, torque the screws to a maximum 15 in-lbs.
- * PAC recommends regular and frequent inspections to maintain of proper operation and installation.

NOTE: This bracket is pre-assembled ready for use. Some adjustments however, may be necessary for proper installation and use. Make any adjustments prior to installation.

STEP 1 – Locate and drill mounting holes through Mini Dual Trac

Position assembled Ironslok bracket in desired location and determine hole locations. Drill 4 holes through the center of the aluminum for PAC TRAC mounting or 2 holes for standard THRU mounting.

LOOSEN, DO NOT REMOVE SCREWS TO ADJUST POSITION.

ADJUST POSITION

DRILL 17/64" HOLES THRU CENTER CHANNEL

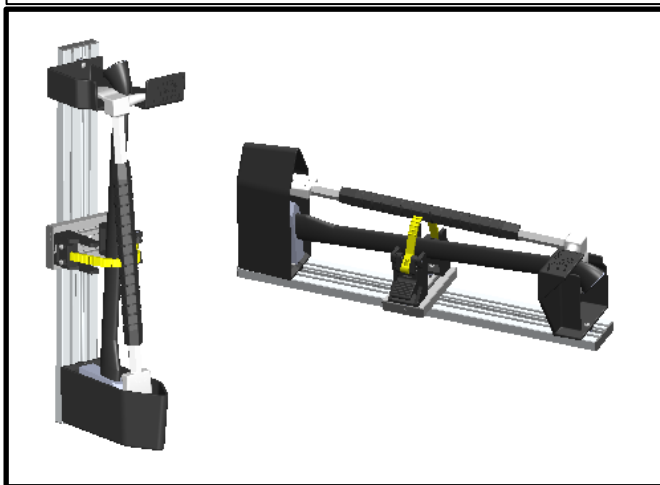

CAN BE MOUNTED HORIZONTALLY OR VERTICALLY

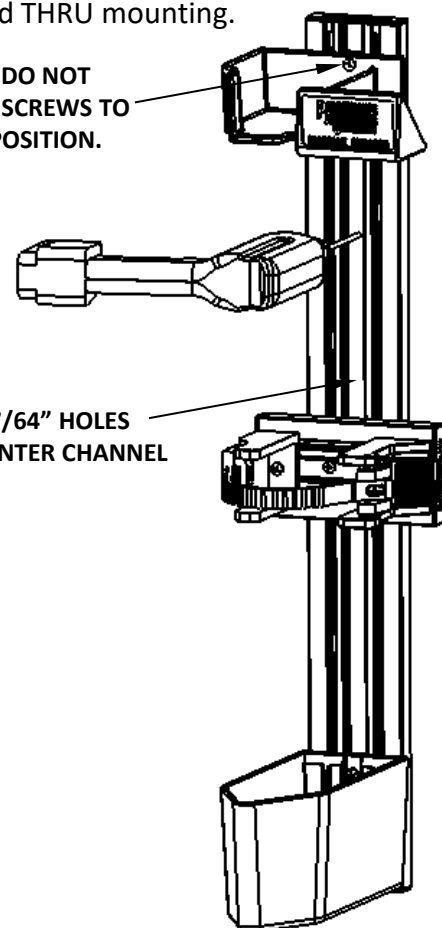
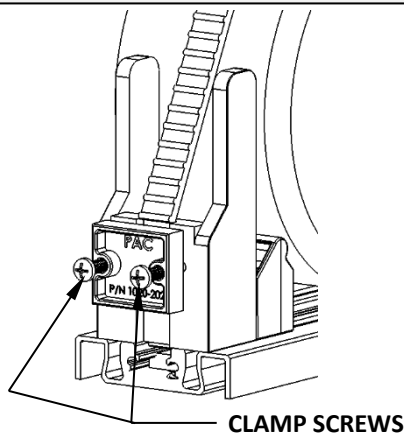

STEP 2 - Adjust strap length to suit equipment. (if necessary)

See document *INS-1020 Fastlok Instruction Sheet* for additional setup information



STEP 3A – Attach bracket to mounting surface. (STD. - BOLT THROUGH)

Attach bracket to mounting surface with included hardware (P/N 2038 hex head screw and P/N 2069LN nut) and tighten securely.

STD. MTG HARDWARE PAC Fastener Packet P/N 2035			QTY
	P/N 3017	¼-20 x 1 S.S. Pan Head Screw	2
	P/N 2069LN	¼-20 S.S. Hex Nut	2

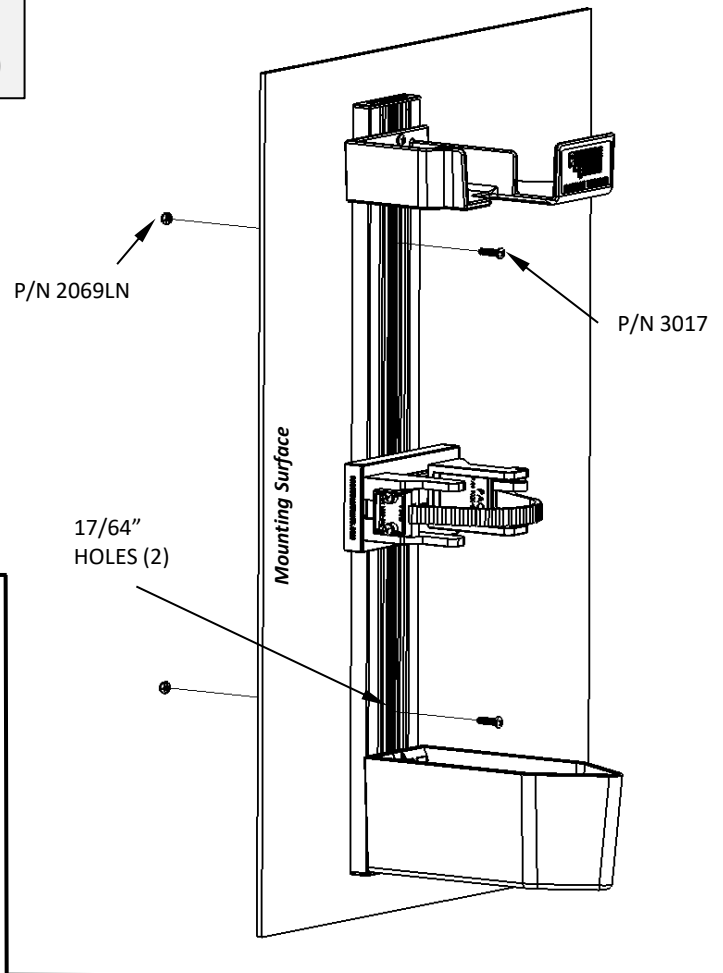

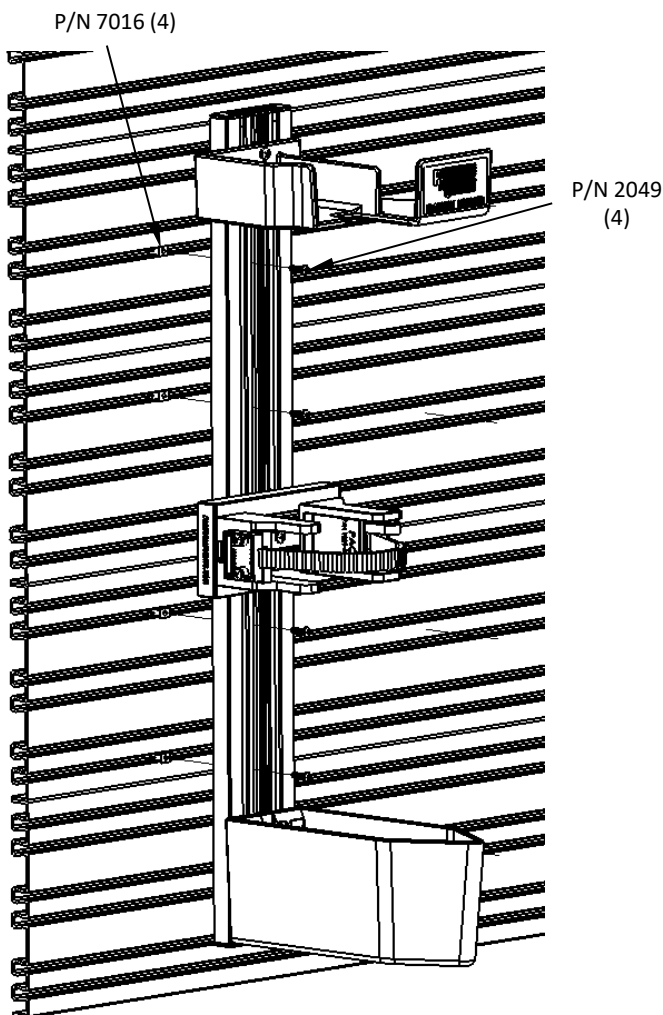

Locate and drill 4 holes in bracket center channel corresponding with grooves in PAC TRAC aluminum boards.



STEP 3B – Attach bracket to mounting surface (PAC TRAC)

Attach bracket to mounting surface with included hardware (P/N 2049 screw and P/N 7016 TracLok insert) and tighten to recommended torque specifications.

NOTE: USE ALL 4 TRAC LOK INSERTS AND SCREWS

PAC TRAC MTG HARDWARE PAC Fastener Packet P/N 7029			QTY
	P/N 2049	#10-24 x 3/4 S.S. Phillips Pan head Screw	4
	P/N 7016	TracLok Insert	4